

**SUPERIOR  
MIXING  
VALVES  
THAT  
CONTROL  
TEMPERATURE  
AND  
ENSURE  
SAFETY**

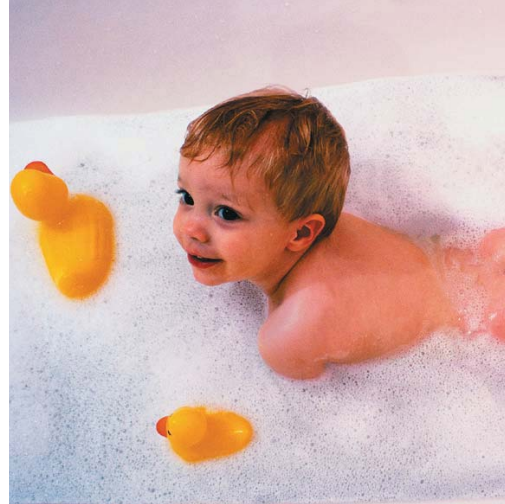

**Thermostatic Mixing Valves**

# AQUABLEND. THE SAFEST WAY TO MIX WATER TO A PRE-SET TEMPERATURE.

Aquablend high-performance Thermostatic Mixing Valves are the only TMVs designed and manufactured in Australia and are supported by more than five decades of Enware's experience and expertise.

## MEETING AUSTRALIAN LEGISLATION: LEADING THE WORLD'S QUALITY STANDARDS

Enware has long believed that absolute quality is crucial to reliable performance and safety. That's why our Aquablend Thermostatic Mixing Valves are Standards marked to AS/NZS4032.1. They also deliver the world's highest standards of quality and durability to allow for AS/NZS3500 compliance.

The healthcare preferred models - Aquablend 1500 and Aquablend 2000, have NSW Health Approval for use in public and private healthcare facilities.

In hospitals, hotels, aged care facilities, homes and commercial applications, where stable-temperature warm water is required, Aquablend safely delivers to plus or minus 2° Celsius – even under changing temperature and pressure conditions. So safety from scalding or shock is ensured by Aquablend's thermal



## AQUABLEND

ENWARE AUSTRALIA PTY LIMITED

shut-off capability in the event of either cold or hot water supply failure.

For showers, baths, basins and sinks – especially where there are young children, elderly or disabled people – Aquablend protects against scald injuries and provides superior temperature stability for warm water delivery.

For optimum performance and reliability Aquablend TMVs are required to be maintained in accordance with the manufacturer's recommendations as stated in the Manual for Installation, Commissioning and Maintenance provided with each valve.



**WaterMark**

AS/NZS 4032.1 Lic1593  
SAI Global



# The versatile Aquablend range – highest standards, exceptional performance.

Flow Characteristics of Aquablend 1000, 1500, 2000 & 2500 with Inlet Fittings  
(With Mix Temperature at 42°C at Valve Outlet)

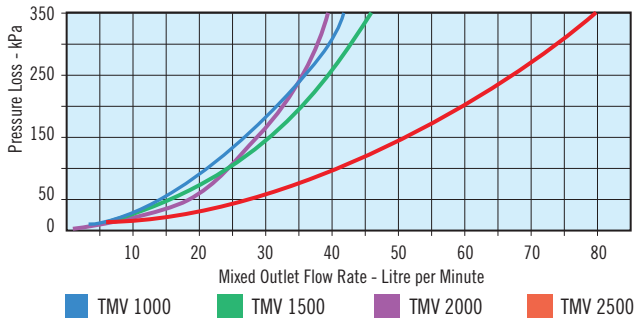

# Multiple Operation

A single Aquablend Thermostatic Mixing Valve can cater for more than one shower, wash basin and bath. Diagram shows schematic of typical healthcare application.

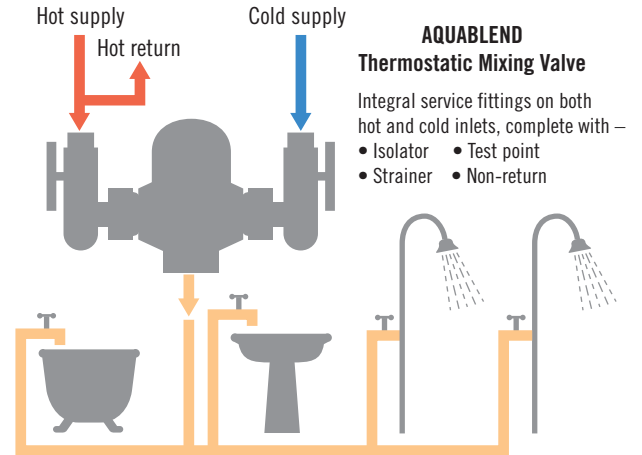

38°C – 45°C to Hospital ensuite (43.5°C max. in NSW HEALTH)  
Refer to local regulations for design requirements

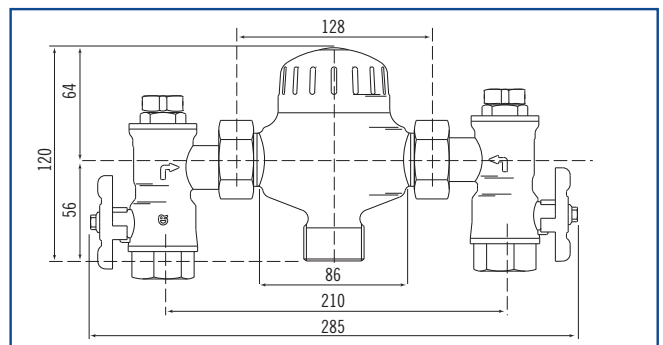
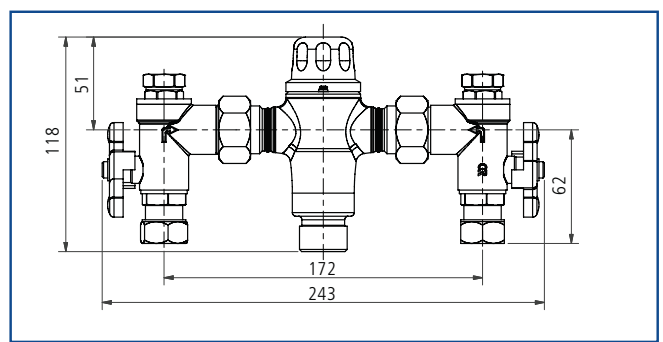
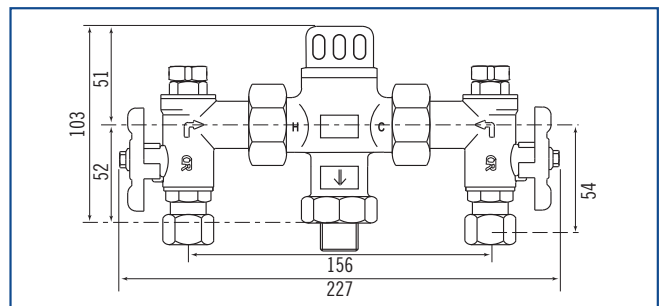
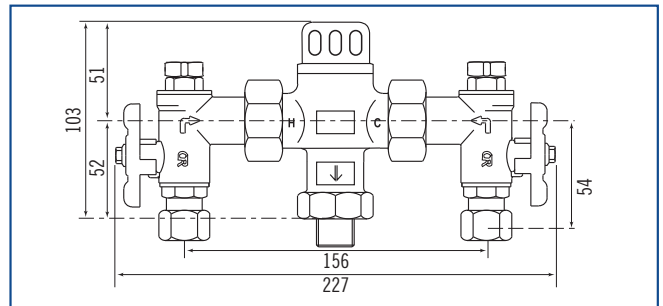
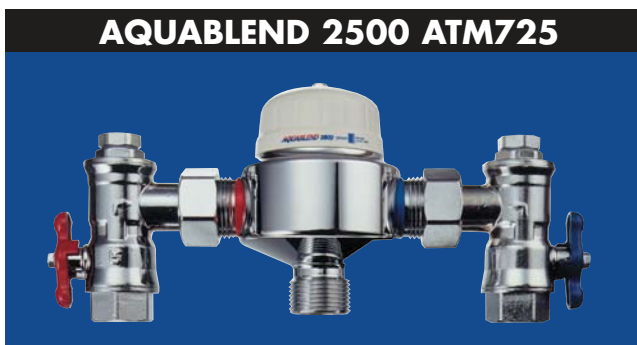
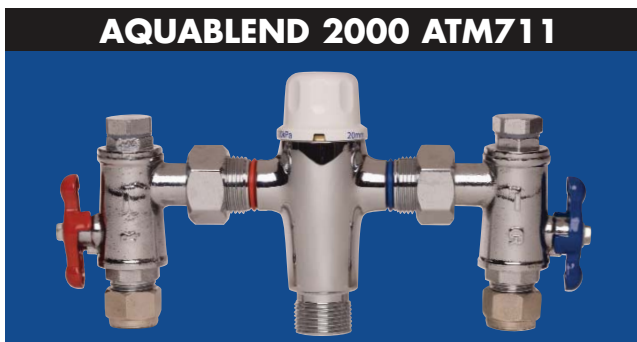

# Handy Test Kit

A practical Thermostatic Mixing Valve Test Kit is now available. The kit comprises of a Digital Thermometer with hand-held Immersion Probe, Pressure Gauge with a spike adaptor, a Flow Cup - and comes complete in a compact carry case of protective contoured foam.

Product Code: **ATMS1200**

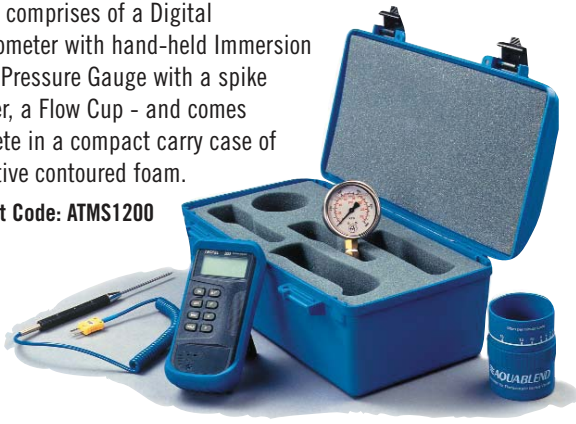

## Technical Specifications Summary

### Aquablend TMV 1000

Product code: **ATM710**  
 Complies with: **AS/NZS4032.1:2005**  
 Temperature Adjustment Range: **38° to 50°C**  
 Dynamic Inlet Pressures: **20kPa Min – 500kPa Max**  
 Static Inlet Pressure: **1600kPa Max**  
 Flow Rates: **39 lpm@300kPa pressure loss**  
 Minimum Flow Rate for stable outlet conditions: **4 litres/min**  
 Pressure Loss Ratio – **5:1 either supply**

Inlet size: **1/2" compression nuts**  
 Outlet size: **1" complete with 1"x1/2" BSP adaptor**  
 Finish: **Nickel plated**  
 Exposed Box code: **ATMS710E**  
 Recessed Box code: **ATMS710R**  
 Wall Bracket code: **ATM728**  
 Access Panel for Box: **ATMS215**  
 O-ring Service Kit code: **ATMS1403**  
 Thermostatic Element/Shuttle Assembly (5 year service) code: **ATMS1400**

### Aquablend TMV 1500

Product code: **ATM700**  
 Complies with: **AS/NZS4032.1:2005, NSW Health Approved**  
 Temperature Adjustment Range: **35° to 48°C**  
 Dynamic Inlet Pressures: **20kPa Min – 500kPa Max**  
 Static Inlet Pressure: **1000kPa Max**  
 Flow Rates: **42 lpm@300kPa pressure loss**  
 Minimum Flow Rate for stable outlet conditions: **4 litres/min**  
 Pressure Loss Ratio – **10:1 either supply**

Inlet size: **1/2" compression nuts**  
 Outlet size: **1" complete with 1"x1/2" & 1"x 3/4" BSP adaptors**  
 Finish: **Nickel plated**  
 Exposed Box code: **ATMS700E**  
 Recessed Box code: **ATMS700R**  
 Wall Bracket code: **ATM728**  
 Access Panel for Box: **ATMS215**  
 O-ring Service Kit code: **ATMS4714**  
 Thermostatic Element/Shuttle Assembly (5 year service) code: **ATMS4715**

### Aquablend TMV 2000

Product code: **ATM711 (Male) ATM713 (Female)**  
 Complies with: **AS/NZS4032.1:2005, NSW Health Approved**  
 Temperature Adjustment Range: **38° to 50°C**  
 Dynamic Inlet Pressures: **20kPa Min – 500kPa Max**  
 Static Inlet Pressure: **1600kPa Max**  
 Flow Rates: **38 litres/minute@300kPa pressure loss**  
 Minimum Flow Rate for stable outlet conditions: **2 litres/min (4 lpm is recommended for optimum performance)**

Pressure Loss Ratio – **10:1 either supply**  
 Inlet size: **1/2" MI comp (ATM711) or 3/4" FI (ATM713)**  
 Outlet size: **3/4" BSP MI**  
 Finish: **Polished and Chrome plated**  
 Exposed Box code: **ATMS216E**  
 Recessed Box code: **ATMS216R**  
 Wall Bracket code: **ATMS214**  
 Access Panel for Box: **ATMS215**  
 O-ring Service Kit code: **ATMS230** (5 year service)  
 Thermostatic Element/Shuttle Assembly (5 year service) code: **ATMS231**

### Aquablend TMV 2500

Product code: **ATM725**  
 Complies with: **AS/NZS4032.1:2005**  
 Temperature Adjustment Range: **35° to 50°C**  
 Dynamic Inlet Pressures: **10kPa Min – 500kPa Max**  
 Static Inlet Pressure: **1000kPa Max**  
 Flow Rates: **75 litres/minute@300kPa pressure loss**  
 Minimum Flow Rate for stable outlet conditions: **6 litres/min**  
 Pressure Loss Ratio – **5:1 either supply**

Inlet size: **3/4" BSP FI**  
 Outlet size: **1" BSP MI**  
 Finish: **Polished and Chrome plated**  
 Exposed Box code: **ATMS727E**  
 Recessed Box code: **ATMS727R**  
 Wall Bracket code: **ATMS714**  
 Access Panel for Box: **ATMS215**  
 O-ring Service Kit code: **ATMS301**  
 Thermostatic Element (5 year service) code: **ATMS306**

## Simple to install and maintain

Aquablend stainless steel enclosure options make accessing and servicing easy, with practical features such as:

- Anti-tamper lockable box with brushed stainless steel cover plate
- Adjustable fascia cover to allow adjustment for wall type covering
- Compact design dimensions to fit into stud work
- Oversized fascia provides flange for recess mounting
- Supplied complete with valve, fully plumbed
- Durable stainless steel construction
- Stainless steel bracket to support valve
- Easy access and servicing in-situ
- Complete with test point on outlet

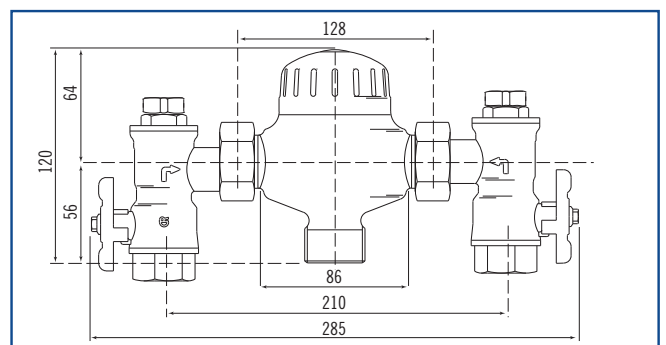
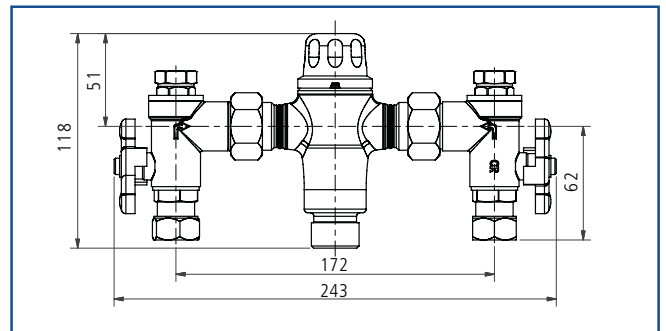
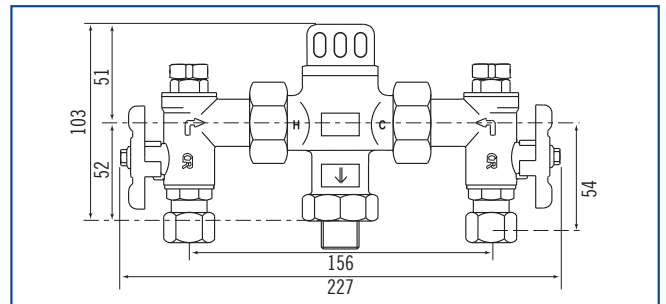
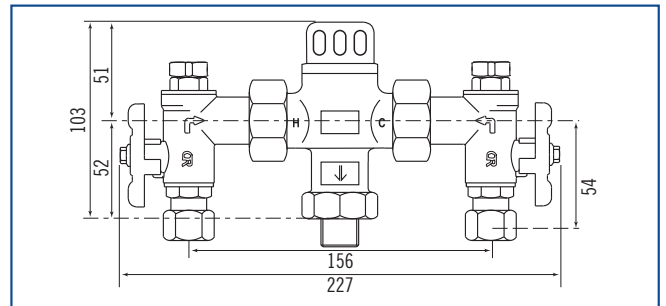

Notwithstanding the TMV technical specifications compliance with AS3500 must be maintained. For optimum performance it is recommended that the inlet pressure be balanced to within + or - 10%. Please note: as Enware's product development is ongoing, product specifications may vary overtime.

## Aquablend TMV Stainless Steel Control Boxes

TMV 2000

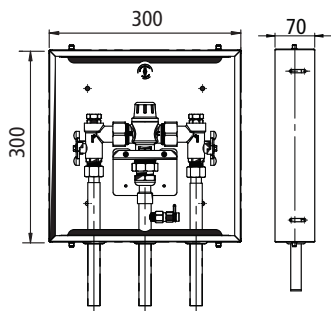

Please quote these codes when ordering

Description	1000	1500	2000	2500
Stainless Steel Box, Exposed – Code	ATMS710E	ATMS700E	ATMS216E	ATMS727E
Stainless Steel Box, Recessed – Code	ATMS710R	ATMS700R	ATMS216R	ATMS727R

To ensure easy access at all times, Aquablend TMVs have removable doors – so installation in confined spaces or close to walls creates no problems.

**Also available: Stainless Steel Access Panel**

350mm x 350mm with anti-tamper screws - **ATMS215**



Stainless Steel Boxes are available in various configurations.



Developed with key engineering and hydraulic consultant partnerships, control boxes which include Cold Water By-Pass and a Hot & Cold Water By-Pass system are available. Please consult our technical staff for specialized configurations.

Please quote these codes when ordering

Description	1000	1500	2000	2500
Cold Water By-Pass (4-Hole) S/Steel Box, Recessed – Code	ATMS119R	ATMS719R	ATMS219R	-

Cold water by-pass (4-Hole) stainless steel box – Exposed is available by request.

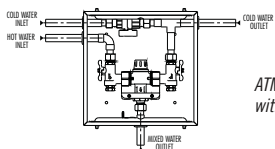

ATMS2009R Aquablend 1000 in a stainless steel box with side inlets with cold water by-pass.

## Performance and Technical Support Guaranteed

Aquablend Thermostatic Mixing Valves are safe, simple and easy to maintain – and provide many features that not only match but exceed industry standards. Some of their proven benefits include:

### Ambient start up control

Ability to control water temperature spikes during ambient start up.

### Thermal Shutdown

The Aquablend TMVs shut down in the event of either Cold water or Hot water supply failure. The valve quickly reinstates flow when normal supply resumes.

### Constant mix control

Water temperature is maintained at plus or minus 2 degrees, even during water temperature or pressure fluctuations.

### Supplied complete

Each unit comes complete with combination isolating ball valve, non-return and dual-stage strainer assemblies which incorporate water pressure/temperature test ports.

### Installation versatility

Each TMV can be installed in any configuration with the water outlet in the horizontal or vertical (up or down) position, and inlet connections can be rotated to suit inlet pipework.

### Easy maintenance

The compact component assembly design allows low-cost, in-situ servicing and ensures minimum down-time. Flat faced connections allow removal of the valve without disturbing the pipework.

### Performance at low pressure

Aquablend is suitable for installation in low pressure systems and will operate with a working pressure as low as 20kPa.

### Safety lockshield

The TMV is supplied as standard with a temperature lockshield to prevent unauthorised changes to the water temperature.

### Technical support

Each TMV is supplied with a detailed technical manual to facilitate valve sizing, installation, commissioning, maintenance and troubleshooting.

By choosing Aquablend TMVs, you are choosing the industry's acknowledged leader in technical support.



# The Enware Smart Flow® TMV monitoring system provides all the information you need, right at your finger tips

Enware Australia's Smart Flow® TMV Monitoring System provides a unique risk management tool for the performance and maintenance of Thermostatic Mixing Valves (TMVs). The networked system constantly monitors the whole system electronically, via a calibrated temperature probe installed into the TMV. It provides engineering personnel with a constant temperature readout and performance status report of all TMVs throughout the facility.

Acknowledging the need by government authorities for the provision of safe guards for patients and carers prompted the development of the Smart Flow® system. It also directly addresses the NSW Department of Health requirement for monthly temperature readings - alleviating this time consuming job and allowing plumbing maintenance staff to focus on more productive activities.

The PC based program provides the user with many features including:

- Constant temperature reading, 24 hours a day
- Alert status audio/visual alarm in the event of a valve operating over temperature
- Automatic logging of TMV history, including individual alert logs
- Interactive password protected maintenance database, which generates reports when annual servicing is due
- Statistical reports providing performance assessment, helps determine level of servicing required for each TMV
- Logs all readings for historical reference, which is third party NATA certified in the event of patient/visitor liability claims
- Full reporting program tailored to the engineering staff requirements



The Smart Flow® system does not alter or change the performance of the TMV in any way, but provides constant temperature readings for analysis.

The Smart Flow®TMV monitoring system is ideal for new installations and may also be retrofitted to existing hospitals or aged care facilities.

For more information about Smart Flow® and how it can integrate into your facility, please contact Enware on 1800 671 864.

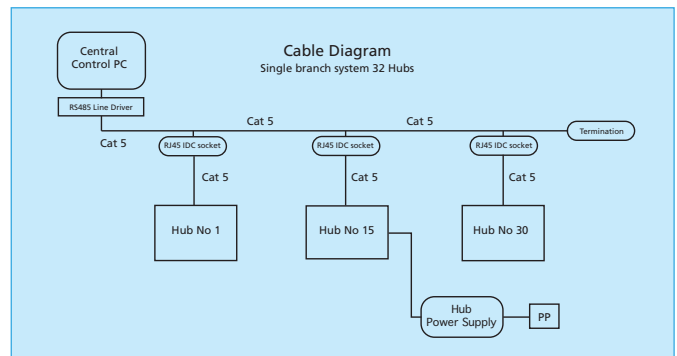

**SPECIALIST TAPWARE** Commercial, Industrial, Hospitals, Schools, Laboratories, Anti-vandal, Food service  
**SAFETY SYSTEMS** Emergency showers & eye/face washes, Decontamination equipment, Spill containment products  
**SPECIALIST WATER SYSTEMS** Thermostatic mixing valves, Electronic tapware, Flush valves, Flow regulation  
**APPLIANCES** Water chillers, Boiling water units, Hand hygiene systems  
**BATHROOM CARE** Specialised adjustable Shower chairs, Support arms, Toilet seats, Basin supports, Grab rails  
**ENVIRONMENTAL** Wash water treatment, Biohazard spill kits and Chemical neutralisation  
**WCS SERVICES** Product Support and Maintenance, Efficiency Analysis and Strategies  
**DISTRIBUTED BY:**



**For more information call 1800 671 864**

9-11 Endeavour Road Caringbah NSW 2229 Australia • PO Box 2545 Taren Point NSW 2229  
 Ph: 61-2-9525 9511 • Fax: 61-2-9525 9536 • Toll Free Phone: 1 800 671 864 • Toll Free Fax: 1 800 633 673

[www.enware.com.au](http://www.enware.com.au) • e-mail: [info@enware.com.au](mailto:info@enware.com.au)